

Technology Leadership Across the Board



**BestCap[®]:
A New Generation of
Low Voltage, Low ESR, Pulse,
Double Layer Capacitors**

A B S T R A C T :

Electrochemical double layer capacitors (EDLCs) produced for back up applications in the last twenty-five years had high Equivalent Series Resistance (ESR) and high loss of capacitance when used in pulse power applications. In addition, the voltages of these devices were limited to less than 5 volts. In 2000, AVX introduced the BestCap[®] line of capacitors to address these limitations to serve the high pulse power market. This paper will present capabilities and subsequent improvements to the BestCap[®] product line.

**Lee Shinaberger, Bharat Rawal,
and Chris Reynolds**

AVX Corporation
PO Box 867

801 17th Ave. South
Myrtle Beach, SC 29577 USA

Phone: 001-843-448-9411

Fax: 001-843-444-2828

BestCap® : A New Generation of Low Voltage, Low ESR, Pulse, Double Layer Capacitors

Lee Shinaberger, Bharat Rawal, and Chris Reynolds

AVX Corporation
 PO Box 867
 801 17th Ave. South
 Myrtle Beach, SC 29577 USA
 Phone: 001-843-448-9411
 Fax: 001-843-444-2828

Introduction

AVX Corporation is a manufacturer of passive components. In 2005, AVX reported revenue of US\$1.28 billion, with the majority of sales coming from multi-layer ceramic and tantalum capacitors. In 1997, AVX invested in the research and development of high capacity electrical storage devices and began to commercialize these products, resulting in the introduction of the BestCap® line of pulse supercapacitors in 2000.

BestCap® capacitors are intended for high-power, pulse applications. Typical applications include GSM and GPRS wireless communication, automatic meter readers, remote valve actuation, and bridging battery chatter. These applications require several amps of current for a few milli-seconds. The BestCap® is used in combination with a battery to provide the momentary high current requirements, with the battery providing the bulk total energy to the system. The battery trickle charges the BestCap® when high currents are not required.

The calculated energy and power for a few select capacitors are included in Table 1, including some of the new capacitors introduced in 2005. Table 2 calculates the energy and power densities for the same capacitors.

Size (mm)	Voltage (V)	Cap. (F)	ESR (*)	Energy (J)	Power (W)
20 x 15 x 2.1	4.5	0.022	0.250	0.2	29.8
28 x 17 x 2.1	3.6	0.050	0.100	0.3	32.4
48 x 30 x 6.1	12.0	0.090	0.090	6.1	216.1
20 x 15 x 2.1 New	4.5	0.047	0.170	0.5	29.8
48 x 30 x 6.1 New	5.5	1.000	0.035	15.1	216.1
195 x 77 x 10 New	16.0	1.500	0.020	192	3,200

Table 1. Energy and Power of Typical BestCap® Products.

Size (mm) (mm)	Volume (cc)	Energy Density (J/cc)	Power Density (W/cc)
20 x 15 x 2.1	0.63	0.4	47.3
28 x 17 x 2.1	1.00	0.3	32.4
48 x 30 x 6.1	8.78	0.7	24.6
20 x 15 x 2.1 New	0.63	0.8	47.3
48 x 30 x 6.1 New	8.78	1.7	24.6
195 x 77 x 10 New	135.14	1.3	21.3

Table 2. Energy and Power Densities of Typical BestCap® Products.

The initial introduction of BestCap® supercapacitors included 4 products: 50, 100, 200, and 400mF at 5.5V. Since initial introduction, over 32 additional capacitance and voltage combinations have been introduced, with 12 combinations becoming available in 2005. This is summarized in Figure 1. Notable product introductions include the B-series of low profile devices in 2001 and expansion into 7, 9, and 12V rated parts in 2002.

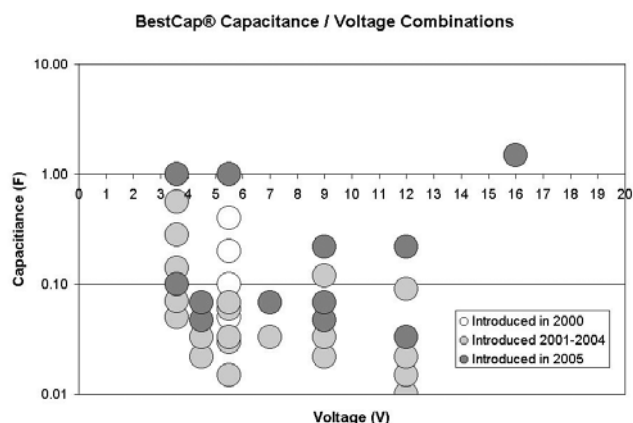

Figure 1: BestCap® Capacitance and Voltage Combinations Available.

Design Considerations

DLCs are typically produced using either aqueous or organic electrolyte systems. While organic electrolytes offer advantages for energy density, they have shortcomings in high pulse power applications. To achieve high voltage, multiple cells must be placed in series. When charged, the voltage distribution across the series of cells must be reasonably uniform. If the voltage in any cell in the series exceeds the capability of the electrolyte, then the device will fail prematurely. Long term reliability depends upon the voltage balancing of the individual cells. Miller and Butler¹ noted that a series of cells with organic electrolytes exhibited a significantly wider voltage distribution than do cells made with an aqueous electrolyte.

In organic systems, individual cells may be tested in order to assemble cells as closely matched as possible, narrowing the voltage distribution across the series. Even then, organic cell manufacturers typically add balancing circuits or resistors to the system. Some manufacturers incorporate these balancing systems into their product, and other manufacturers require their customers to add external balancing resistors. These balancing circuits significantly increase the leakage current of the DLC system.

In aqueous systems like those used by BestCap[®], no voltage balancing circuit is required because cell to cell voltage differences are negligible. This results in parts with lower leakage currents than organic systems.

The greatest advantage of the aqueous system is the flexibility allowed in increasing the voltage rating of the DLC system. While organic systems become complex when multiple cells are placed in series, there is no significant change in the complexity of an aqueous system. Whenever a higher voltage is required, another cell is added to the series. AVX routinely produces BestCap[®] parts with 16 cells in a series, and products with 22 cells have been delivered to customers.

The lack of a balancing circuit has no effect on the long-term reliability of the part. At the end of this article, several graphs are shown to illustrate the reliable nature of BestCap[®] double layer capacitors. These include results after 2,000 hours at 70°C with rated voltage applied, results after 10 million cycles of deep discharge, and 5,000 hours at 40°C and 95% humidity (rated voltage applied).

Developments in 2005

AVX pursued three development goals for 2005. These included increasing the energy density, finding an alternative way to attach to the printed circuit board (PCB), and expanding the BestCap[®] product line to higher power applications.

Increased Energy Density

As discussed previously, organic electrolyte systems have higher energy density than aqueous systems. Because the individual organic cell operates at 2.2-2.7V, multiple aqueous cells at 1.0V must be placed in series to achieve equivalent voltage ratings, with each cell in series lowering the overall capacitance. In order to address the issue of energy, AVX has pursued a plan to double the capacitance and hence the energy density of its capacitors.

The first steps pursued were to evaluate new carbons recently introduced to the market. Several carbon manufacturers were approached, and many carbons were tested. AVX noted that substantial progress had been made in carbon development since the BestCap[®] was introduced. Most of the carbons tested possessed a much higher surface area per unit volume, and hence an improved energy density. The critical areas evaluated were the ease of in the existing BestCap[®] process, ESR of the finished product, and price. After evaluating over 100 lots, a formulation was found that yielded at least double the capacitance in the same unit volume. Table 3 shows the change in energy for some selected parts. The slight variations in the ratios of the capacitance increase are caused by efforts to standardize on E-6 capacitance values.

Voltage (V)	ESR (*)	Standard Part #	Cap (F)	High Energy Part #	Cap (F)
3.6	0.100	BZ013B503ZSBAJ	0.050	BZ113B104ZSBAJ	0.100
4.5	0.170	BZ054B223ZSBBQ	0.022	BZ154B473ZSBBQ	0.047
5.5	0.080	BZ015A104ZSB	0.100	BZ115A224ZSB	0.220

Table 3. Capacitance Increase with High Energy Electrode Formulations – Selected Parts.

AVX has met its goal of doubling the energy density of its BestCap[®] product line. This has resulted in several new customers and design wins.

Alternative Attachment to the PCB

One of the biggest disadvantages experienced by pulse double layer capacitors is the requirement of hand soldering to the PCB. The BestCap[®] product development team has teamed up with the AVX/Elco division (connectors) to deliver the market's first high pulse power double layer capacitor that does not require hand soldering.

A connector is added to the board using a standard IR reflow process. Assemblers remove a liner from the BestCap[®] to expose a layer of adhesive. The part is inserted into the connector, then pressed down to attach the adhesive to the PCB. This attachment method is similar to that used by batteries, making it familiar to production personnel.

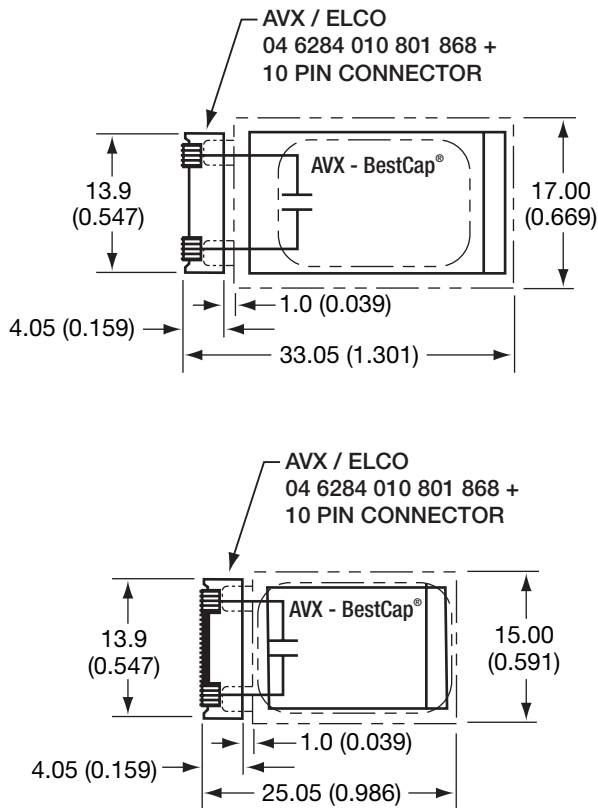

Figure 2: BestCap® with Connector – BZ01 (28x17mm) and BZ05 (20x15mm) PCB Layout.

Figure 2 shows the PCB layout of the BZ01 (28x17mm size) and BZ05 (20x15mm) BestCap® products that are currently available with a connector lead. Using the lead code “C” in the part number specifies the connector version.

The primary design issue with adding the connector capability to the BestCap® was the ability to keep the added ESR as low as possible. With many BestCap® products possessing an ESR of less than 100 milli-Ohms, even 10 milli-Ohms of additional ESR from the connector was deemed unacceptable. By providing multiple contacts at each lead, AVX was able to lower the average ESR increase to a mere 2 milli-Ohms, well below our design goal of 5 milli-Ohms.

AVX has met its design goal of introducing a connector version of BestCap® to the marketplace. This innovation has addressed one of the critical hurdles to widespread use of pulse double layer capacitors, the need for hand soldering. While this product has not been in the marketplace very long, the initial response has been overwhelmingly positive.

The “Brick”: Expanding High Power Capability

Generally development projects are primarily in response to market forces. The next project was initiated while thinking about what AVX does best versus our competitors. The answer is simple: relatively high voltage capability coupled with low ESR. This is the basis for our high power BestCap® products. A prototype part was produced to push the voltage and ESR significantly beyond what AVX had built to date. The prototype part was 16V, 1.5F, with an ESR of 20 milli-Ohms. The prototype is shown in Figure 3 along with the standard size BestCap® parts.

While this part easily dwarfs even the large 48x30mm size shown in the middle of the photograph, overall it is a relatively small 195x77x10mm. With 3,200 Watts of power, it is capable of delivering a great deal of current.

While the “Brick” BestCap® has not been formally released to the market, prototypes have been demonstrated to gauge customer interest. The exceptional amount of power stored promises to provide a niche market for this unusual part, and a few small orders have been accepted. Full production capability is scheduled for the end of 2005.

Mounting Procedure on a PCB for BestCap®



Figure 3: “Brick” BestCap® with BZ01, BZ02, and BZ05 part sizes.

BestCap® products can be mounted on PCBs by either selectively heating only the capacitor terminals by using a pulsed reflow soldering station or by using hand soldering. IR Reflow or wave soldering may not be used. The main body of the device should be less than 60°C at all times.

Pulsed Reflow Soldering

Application data for the 'Unitek' pulsed-reflow soldering station.

Equipment:

Controller	Uniflow 'Pulsed Thermode Control'
Head	Thin-line Reflow Solder Head

Solder paste type	No Clean Flux
Solder composition	63% SN, 37% Pb
Percent solids	88%
Solder thickness	6 mils
Solder-weld tip size	0.075"
Solder-weld tip force	6 lbs.

Temperature profile:

	Temperature	Time
Pre-heat	130°C	0 sec.
Rise	440°C (±10)	2 sec.
Reflow	440°C (±10)	2 sec.
Cool	165°C	

Hand Soldering Station

Equipment: Temperature controlled, 50W general purpose iron

Solder type: 63Sn/37Pb, rosin core wire

Temperature: 400°C (+20°C - 100°C)

Time: 2 to 5 seconds maximum, smaller time (2 sec.) at 420°C and 5 sec. at 300°C, overall it being a time-temperature relationship. Shorter time, higher temperature is preferred.

Solder Type: Lead Free, 95Sn/5Ag

Temperature: 430°C (+20°C - 100°C)

Time: 2 to 5 seconds maximum, smaller time (2 sec.) at 420°C and 5 sec. at 300°C, overall it being a time-temperature relationship. Shorter time, higher temperature is preferred.

In both cases, the main body of the BestCap® part should be less than 60°C at all times.

Performance Characteristics

Change in Capacitance
(70°C, with Rated Voltage Applied)

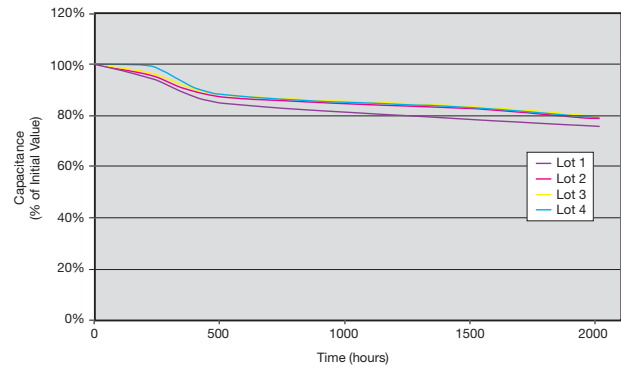

Change in Leakage Current
(70°C, with Rated Voltage Applied)

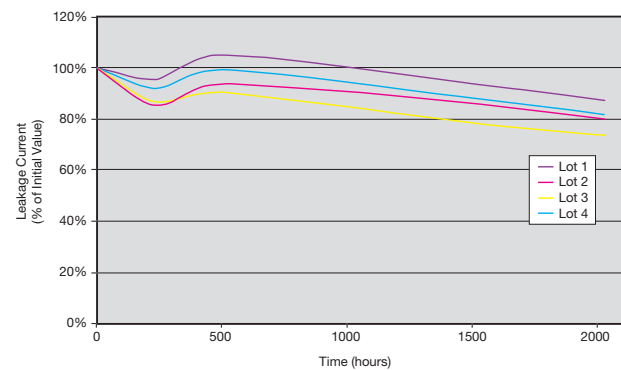

Change in ESR
(70°C, with Rated Voltage Applied)

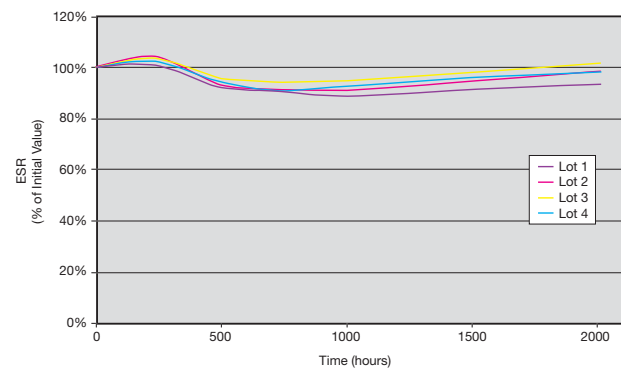

**Cycle Life, 10 million cycles
Capacitance**

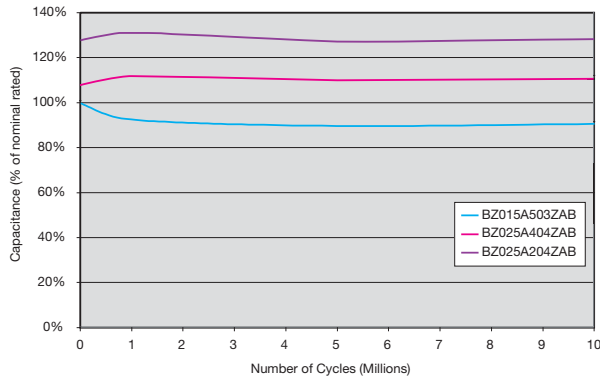

**40°C / 95% Humidity, Rated Voltage Applied
Capacitance**

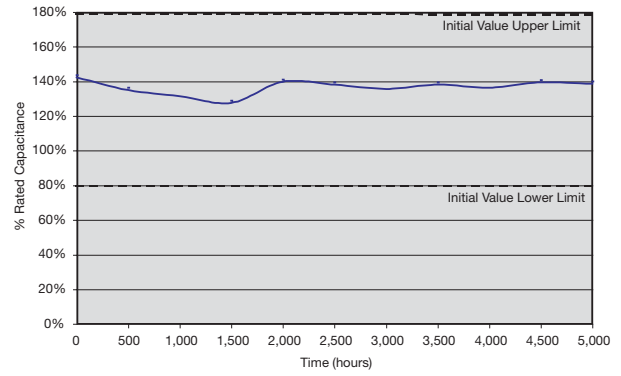

**Cycle Life, 10 million cycles
Leakage Current**

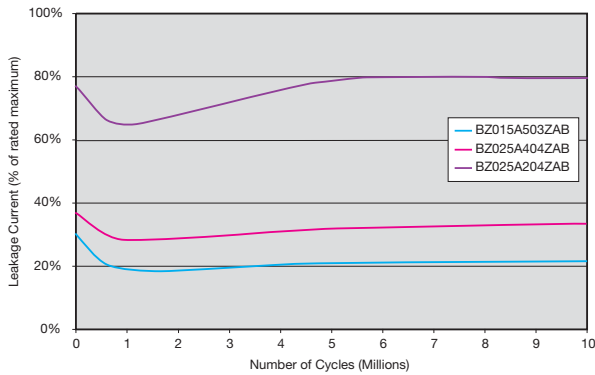

**40°C / 95% Humidity, Rated Voltage Applied
Leakage Current**

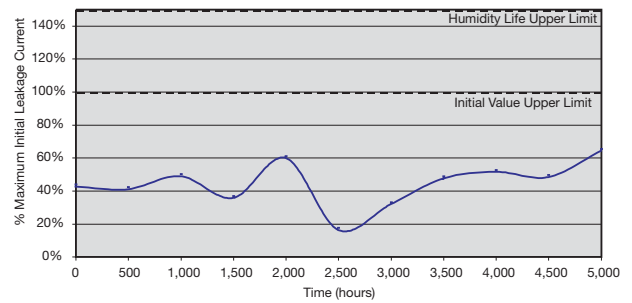

**Cycle Life, 10 million cycles
ESR**

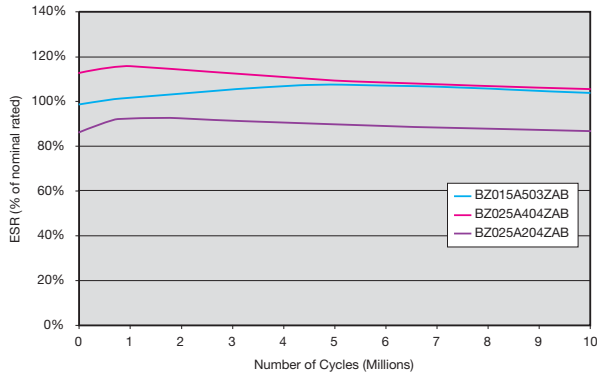

**40°C / 95% Humidity, Rated Voltage Applied
ESR**

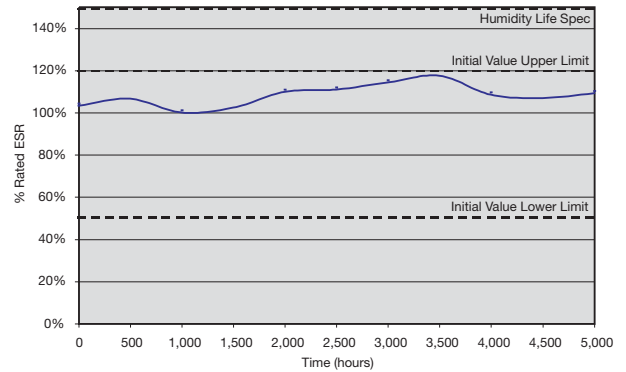

Conclusion

In 2005, AVX continued its commitment to innovation. In the BestCap® product line, additional products were introduced with double the amount of energy storage capability in the same package size. AVX also introduced the market's first pulse double layer capacitor with connector attachment to the PCB with the C-lead version of the BestCap®. Finally, AVX has demonstrated the capability to produce a 16V BestCap® with 3,200 Watts of power. Full production capability for the "Brick" BestCap® is expected by the end of the year.

References

1. J. R. Miller and S. M. Butler, "Electrochemical Capacitor Float-Voltage Operation: Leakage Current Influence on Cell Voltage Uniformity," Proc. 11th International Seminar on Double Layer Capacitors and Similar Energy Storage Devices, Deerfield Beach, Florida (December 3-5, 2001).

USA

AVX Myrtle Beach, SC
Corporate Offices
Tel: 843-448-9411
FAX: 843-448-1943

AVX North Central, IN
Tel: 317-848-7153
FAX: 317-844-9314

AVX Southwest, AZ
Tel: 602-678-0384
FAX: 602-678-0385

AVX Southeast, GA
Tel: 404-608-8151
FAX: 770-972-0766

AVX Northwest, WA
Tel: 360-699-8746
FAX: 360-699-8751

AVX Mid/Pacific, CA
Tel: 510-661-4100
FAX: 510-661-4101

AVX South Central, TX
Tel: 972-669-1223
FAX: 972-669-2090

AVX Canada
Tel: 905-238-3151
FAX: 905-238-0319

EUROPE

AVX Limited, England
European Headquarters
Tel: ++44 (0) 1252-770000
FAX: ++44 (0) 1252-770001

AVX/ELCO, England
Tel: ++44 (0) 1638-675000
FAX: ++44 (0) 1638-675002

AVX S.A., France
Tel: ++33 (1) 69-18-46-00
FAX: ++33 (1) 69-28-73-87

AVX GmbH, Germany
Tel: ++49 (0) 8131-9004-0
FAX: ++49 (0) 8131-9004-44

AVX srl, Italy
Tel: ++390 (0)2 614-571
FAX: ++390 (0)2 614-2576

AVX Czech Republic
Tel: ++420 465-358-111
FAX: ++420 465-323-010

ASIA-PACIFIC

AVX/Kyocera, Singapore
Asia-Pacific Headquarters
Tel: (65) 6286-7555
FAX: (65) 6488-9880

AVX/Kyocera, Hong Kong
Tel: (852) 2-363-3303
FAX: (852) 2-765-8185

AVX/Kyocera, Korea
Tel: (82) 2-785-6504
FAX: (82) 2-784-5411

AVX/Kyocera, Taiwan
Tel: (886) 2-2698-8778
FAX: (886) 2-2698-8777

AVX/Kyocera, Malaysia
Tel: (60) 4-228-1190
FAX: (60) 4-228-1196

Elco, Japan
Tel: 045-943-2906/7
FAX: 045-943-2910

Kyocera, Japan - AVX
Tel: (81) 75-604-3426
FAX: (81) 75-604-3425

Kyocera, Japan - KDP
Tel: (81) 75-604-3424
FAX: (81) 75-604-3425

AVX/Kyocera, Shanghai, China
Tel: 86-21 6341 0300
FAX: 86-21 6341 0330

AVX/Kyocera, Beijing, China
Tel: 86-10 8458 3385
FAX: 86-10 8458 3382

Contact:

NOTICE: Specifications are subject to change without notice. Contact your nearest AVX Sales Office for the latest specifications. All statements, information and data given herein are believed to be accurate and reliable, but are presented without guarantee, warranty, or responsibility of any kind, expressed or implied. Statements or suggestions concerning possible use of our products are made without representation or warranty that any such use is free of patent infringement and are not recommendations to infringe any patent. The user should not assume that all safety measures are indicated or that other measures may not be required. Specifications are typical and may not apply to all applications.

© AVX Corporation



<http://www.avx.com>

S-BC00M1005-N